

ASSEMBLY INSTRUCTIONS FOR PIVOTING ROLL-AROUND WHITEBOARD - Part # 78790

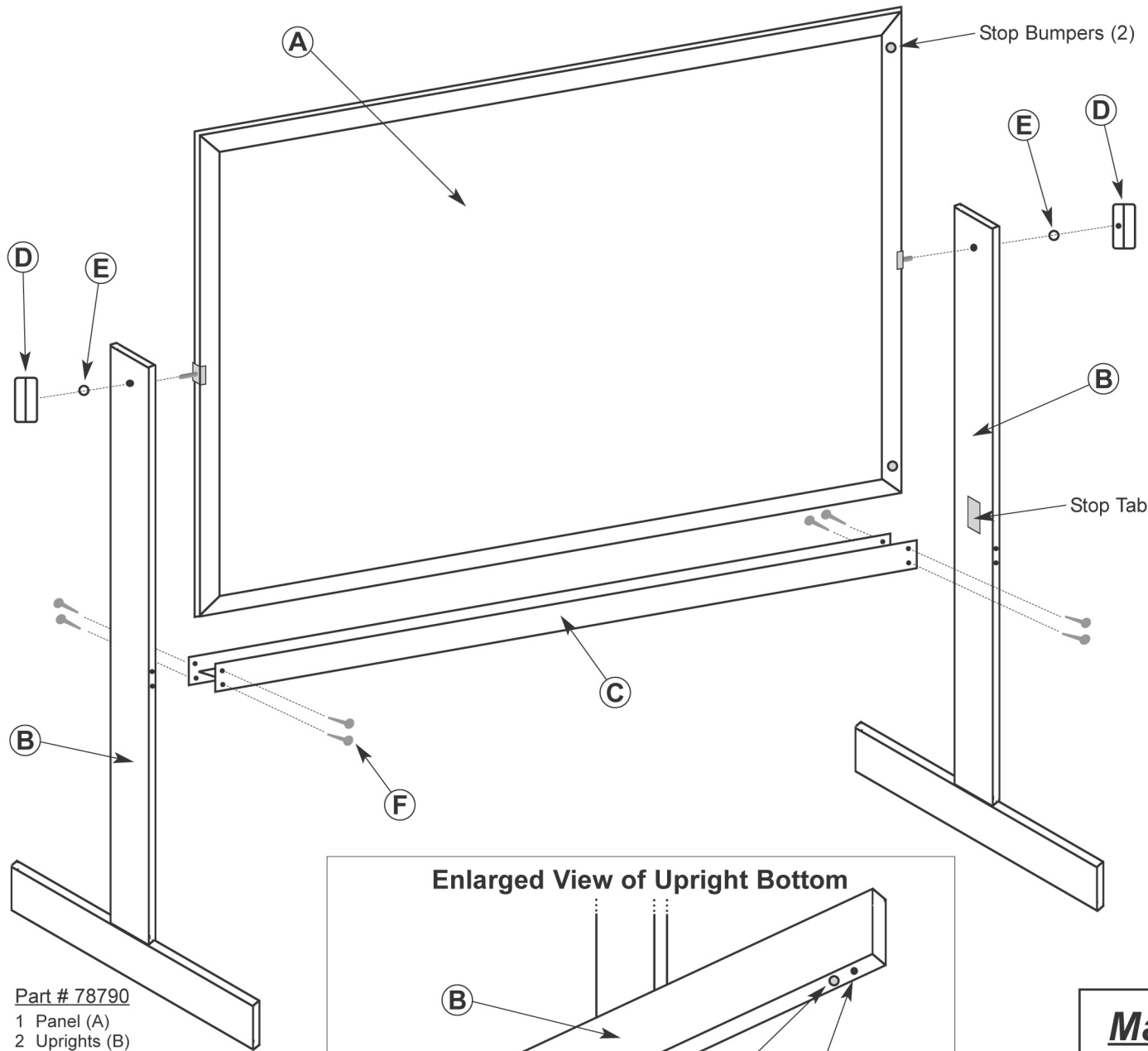

1. Lay reversible Panel (A) on a raised flat surface (desk, table, etc.).
2. Position holes in Uprights (B) onto Pivot Bolts at each end of Panel. Make sure the Upright with Stop Tab is facing inward and adjacent to the end of the Panel having the two Stop Bumpers.
3. Place Washers (E) on outside of each Upright onto the Pivot Bolts and screw Locking Knobs (D) onto Pivot Bolts until Upright is just touching the side of Panel. DO NOT OVERTIGHTEN.
4. Place Chalkthrough (C) onto Uprights (B) and align with pre-drilled holes. Tighten the eight Screws (F) until the heads just touch the Chalkthrough surface. Check unit for squareness (before tightening Screws) - gap between Panel and Upright should be uniform from top to bottom on both sides. When unit is square, tighten all Screws.
5. If required, install Casters by tapping Caster Sleeves into Holes (G). Unscrew Glides (H) to remove. Insert Caster Stems into Caster Sleeves (in the Holes).
6. Tighten Locking Knobs (D) uniformly at each end until Panel does not pivot freely.
7. Place unit on floor - it is now ready for use.
8. To pivot the Panel: loosen the Locking Knobs (D) slightly, pivot Panel to display opposite side of board, and re-tighten Locking Knobs to secure.

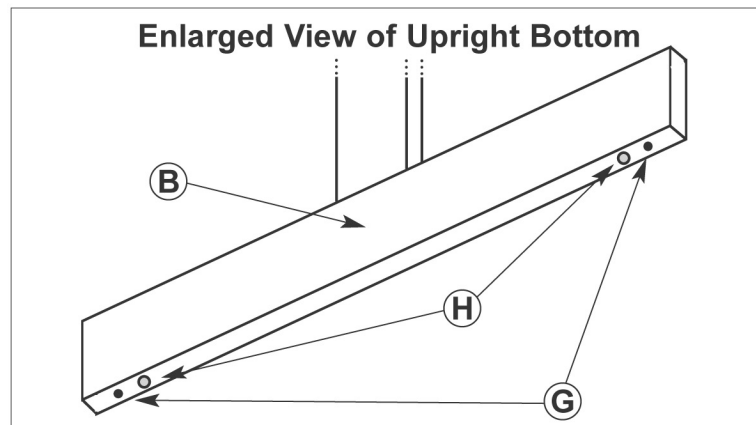

Part # 78790

- 1 Panel (A)
- 2 Uprights (B)
- 1 Chalkthrough (C)
- 2 Locking Knobs (D)
- 2 Washers (E)
- 8 Screws (F) with pre-drilled holes
- 4 Pre-drilled caster holes (G)
- 4 Upright Glides (H)
- Optional:
- 4 Casters and sleeves

For assembly questions or to order whiteboard supplies, contact Magnetic Concepts Corp.

Magnetic Concepts Corp.

611 3rd Avenue SW
Carmel, IN 46032 USA

web: www.bigboards.com
phone: 800-334-4245 fax: 317-580-4024